

### Cramping sets Type FGH, hot-dip galvanised

#### Application

- For fastening suspended MÜPRO pipe slides below subconstructions of steel profiles
- Suitable for guides with lift lock for installing suspended pipe slides
- Hot-dip galvanised version for indoor and outdoor use
- For pipe slides with a base plate up to 15 mm thick

#### Your benefits

- Pre-assembled sets comprising cramping elements and the corresponding installation parts and cramping angles for fastening a pipe slide on the subconstruction

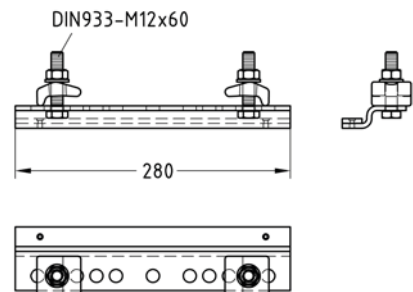
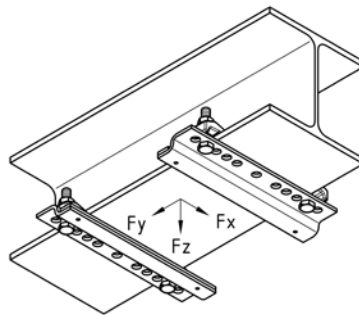
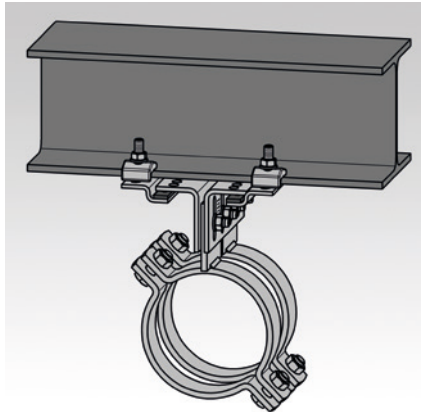

Type	Max. flange thickness [mm]	Support profile thickness [mm]	Load			Thread	Max. tightening torque [Nm]	Weight [kg/item]	Item no.	Supply unit	Quantity unit
			F <sub>x</sub> [kN]	F <sub>y</sub> [kN]	F <sub>z</sub> [kN]						
Type FGH, with sliding plate	26	100–180	–	±3.0	±8.0	M12	22	2.274	168855	1	Set

 Suitable for pipe slides with a base plate up to 15 mm thick.

Standard	Profile type	Designation	
		Min.	Max.
DIN 1025-3	HE-A	HE-A 100	HE-A 180
DIN 1025-2	HE-B	HE-B 100	HE-B 180
DIN 1025-1	I	I 80	I 475
DIN 1025-5	IPE	IPE 80	IPE 400
DIN 1025-4	HE-M	HE-M 100	HE-M 180
EN 10055	T	T 80	T 140