

Cramping sets

Types FG and F, hot-dip galvanised

Application

- For fastening MÜPRO pipe slides on subconstructions of steel profiles
- Suitable as guide (expansion point) without lift lock
- Hot-dip galvanised version for indoor and outdoor use
- Suitable for all MÜPRO pipe slides

Your benefits

- Pre-assembled sets comprising cramping elements and the corresponding threaded pins and nuts for fastening a pipe slide on the subconstruction



Type FG, with sliding plate

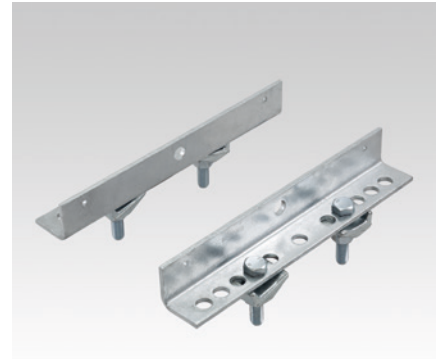

Type F, without sliding plate

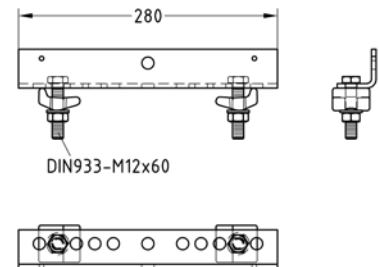
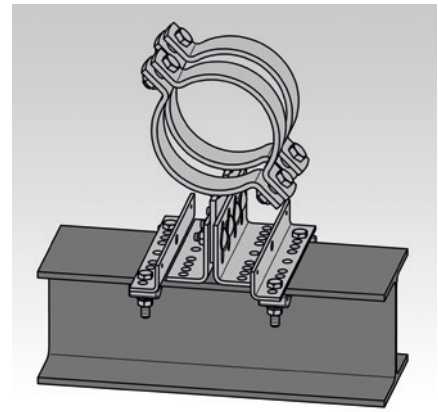
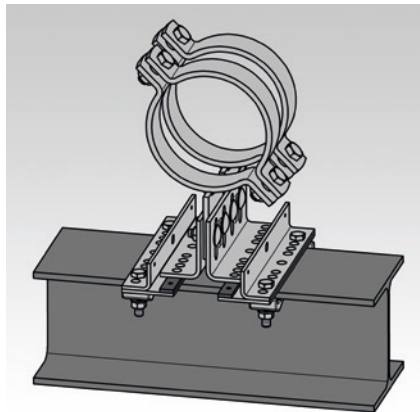
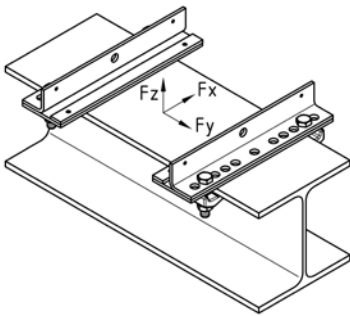

Type	Max. flange thickness [mm]	Support profile thickness [mm]	Load			Thread	Max. tightening torque [Nm]	Weight [kg/item]	Item no.	Supply unit	Quantity unit
			F_x [kN]	F_y [kN]	F_z [kN]						
Type F, without sliding plate	26	100–180	–	± 3.0	–	M12	22	2.204	169474	1	Set
Type FG, with sliding plate			3.818	169478							

Standard	Profile type	Designation	
		Min.	Max.
DIN 1025-3	HE-A	HE-A 100	HE-A 180
DIN 1025-2	HE-B	HE-B 100	HE-B 180
DIN 1025-1	I	I 80	I 475
DIN 1025-5	IPE	IPE 80	IPE 400
DIN 1025-4	HE-M	HE-M 100	HE-M 180
EN 10055	T	T 80	T 140