

### MPC-Wall hanger supports without vibration control, galvanised

#### Field of application

- For wall mounting of air-conditioning units where no vibration damping is required
- Galvanised version for use in dry interiors

#### Advantages

- Efficient mounting due to pre-assembled parts
- MPC-Support channels cut-to length and with holes on the rear side including MPC-Protection caps

- Various bracket lengths available (depending on device type)
- Simple height adjustment of the brackets due to sliding MPC-Hammer head bolts
- Variable adjustment of the mounting spaces on the bracket due to MPC-Rail nuts



#### Features

Length L [mm]	Max. recommended load (set) [N]
480	1,500
560	
640	
800	1,200
1.040	0,900

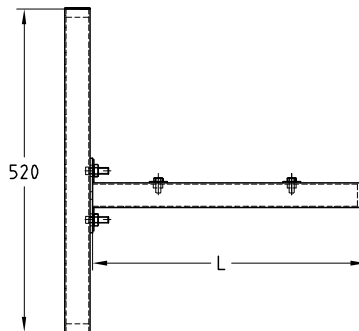

Complete kit consists of:

- 2 MPC-Support channels 38/40, length 520 mm
- 2 MPC-Wall hanger brackets 38/40
- 6 MPC-Protection caps for 38/40 profile
- 4 MPC-Hammer-head bolts M10/30
- 4 Washers 8.5 x 36 x 2 mm
- 4 MPC-Rail nuts M8 for 38/40 profile
- 4 Hexagon head bolts M8/20
- 4 MPC-Clamp brackets M10 for 38/40 profile

Length L [mm]	Part no.	Sales unit	Pack unit
480	113538	1	set
560	113544		
640	113547		
800	113550		
1.040	113535		