

MPT-Brackets

hot-dip galvanised

Application

- Hot-dip galvanised brackets for support and bracing of 90° corner connections of MPT support structures

Your advantages

- High corrosion protection due to standardised hot-dip galvanising ensures flexible implementation outdoors and indoors
- Fast bracing of corner connections by using two fastening points only
- Easy and safe to install, oblong holes easily compensate for any installation tolerances that may occur

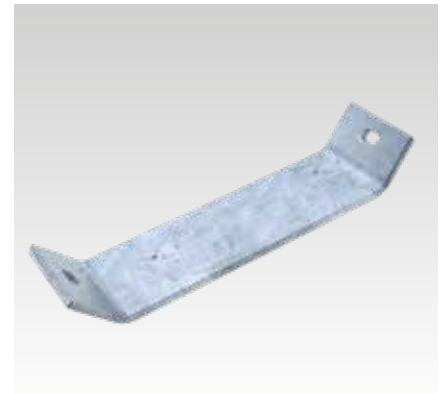
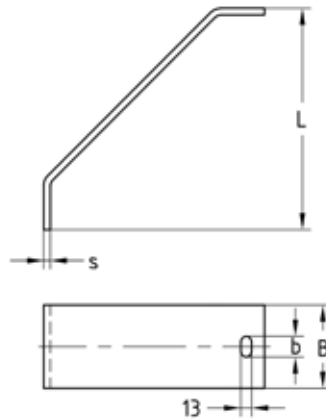

Light version

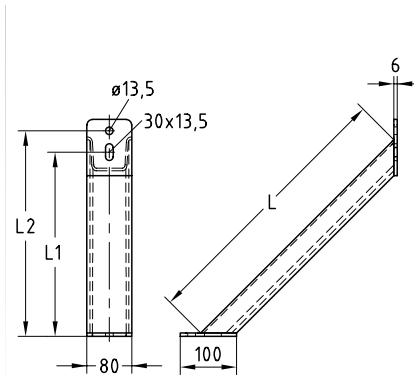

Heavy-duty version



Design	For profiles	Thickness s [mm]	Dimensions [mm]					Weight [kg]	Part no.	Sales unit	Pack unit
			b	B	L	L1	L2				
Light version	Q50-2.5, Q100-2.5, Q100-3.5, Q150-2.5	8	25	100	290	-	-	2.82	131835	1	Pieces
	Q80-2.0		30	80	235	-	-	1.736			
Heavy-duty version	Q50-2.5, Q80-2.0, Q100-2.5, Q100-3.5, Q150-2.5	6	-	-	485	330	368	4.258	176054	1	Pieces
			-	-	909	630	668	7.677			

 The combination of MPT-Brackets (light version) and the profile Q150-2.5 is limited.