

MPR-Girder cleats

hot-dip galvanised

Application

- Attachment of MPR-Support channels to steel girders without drilling or welding
- For indoor and outdoor use

Your advantages

- Ideal solution for attachment of MPR-Support channels to steel girders
- Allows subsequent adjustment of the channels along and across the supporting beam
- Suitable for flange thicknesses of common support profiles
- Easy to install, pre-assembled kit
- Proper attachment of suspended loads on girders

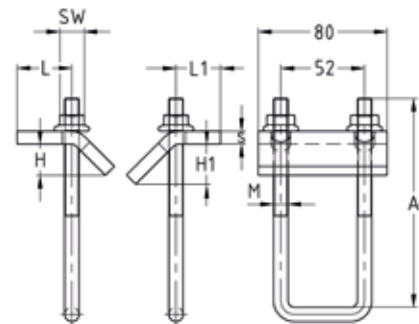
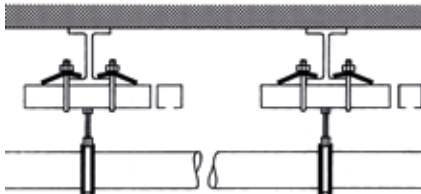
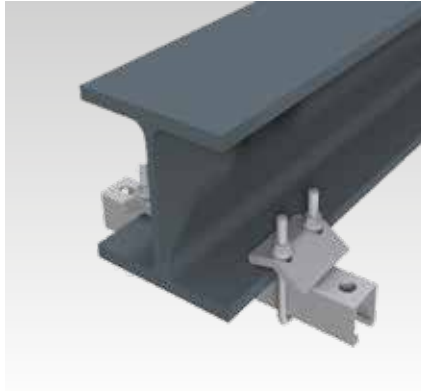

Features

For profiles	Thread U-brackets	Max. permitted loading/pair with hammer head fasteners [N]			
		M8	M10	M12	M16
41/21/2.0, 41/41/2.0, 41/42/2.0	M8	4,500	4,500	4,500	4,500
41/21/2.0, 41/41/2.0, 41/42/2.0	4,500	4,500	4,500		
				41/41/2.5	5,000
41/62/2.5	4,500	4,500	4,500		
				41/82/2.5	5,000
41/124/2.5	4,500	4,500	4,500		

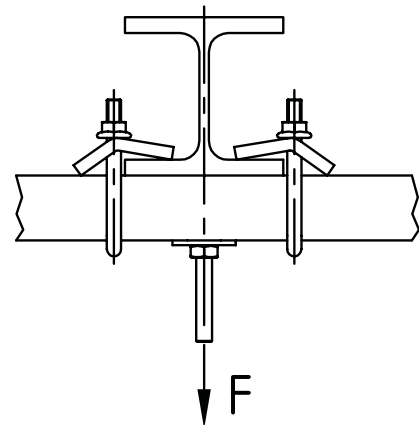

For profiles	Max. clamping thickness [mm]	Thread	Spanner width [mm]	Dimensions [mm]						Part no.	Sales unit	Pack unit
				A	H	H1	L	L1	s			
41/21, 41/41, 41/42	22	M8	13	90	18.5	24.5	34	30	6	154232	10	Pieces
		M10	15	130	154230							
41/62, 41/82	170	154231										
41/124	170	154233										