

Saddle clamps

hot-dip galvanised

Application

- Fastening uninsulated pipes to support channels, consoles and frame structures in commercial and industrial applications
- Execution according to VdS CEA 4001 for water extinguishing systems
- Suitable for outdoor use

Your advantages

- Suitable for standing and hanging installations
- Easy installation into the rail slot using hexagon head bolts and rail nuts
- High corrosion protection
- Alternative to U-bolts
- For use in retrofit and new construction applications



Features

Size	Max. recommended tensile load Fz [N]
17.2 - 48.3 mm	5,000
60.3 - 88.9 mm	7,500
114.3 - 219.1 mm	10,000
273 mm	12,500
323.9 mm	15,000

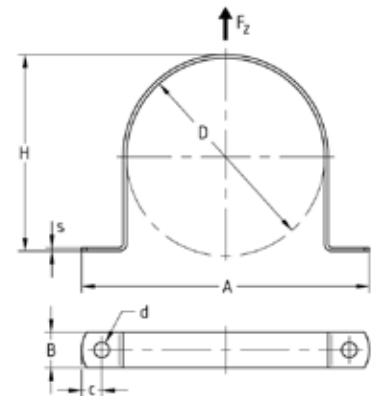

Pipe outer Ø D [mm]	Hole diameter d [mm]	s	Dimensions [mm]		Part no.	Sales unit	Pack unit
			B	H			
17.2	11	2.5	30	15.7	176687	50	Pieces
21.3				19.8	176688		
26.9				25.4	176689		
33.7				32.2	176690		
42.4				40.9	176691		
48.3				46.8	176692		
60.3				58.8	176693		
76.1				74.6	176694		
88.9				87.4	176695		
114.3				13	3		
139.7	138.7	176697	10				
168.3	167.3	176698					
219.1	218.1	176699					
273	272	176700	1				
323.9	18	4	50	323.9	176701		